

## Experimental studies of Savonius wind turbines with variations sizes and fin numbers towards performance

Ilham Satrio Utomo, Dominicus Danardono Dwi Prija Tjahjana, and Syamsul Hadi

Citation: *AIP Conference Proceedings* **1931**, 030041 (2018); doi: 10.1063/1.5024100

View online: <https://doi.org/10.1063/1.5024100>

View Table of Contents: <http://aip.scitation.org/toc/apc/1931/1>

Published by the *American Institute of Physics*

---

### Articles you may be interested in

[Review of the Savonius rotor's blade profile and its performance](#)

*Journal of Renewable and Sustainable Energy* **10**, 013306 (2018); 10.1063/1.5012024

[Experimental study of two-stage Savonius rotors with different gap ratios and phase shift angles](#)

*Journal of Renewable and Sustainable Energy* **8**, 063302 (2016); 10.1063/1.4966706

[Effect of blades number to performance of Savonius water turbine in water pipe](#)

*AIP Conference Proceedings* **1931**, 030046 (2018); 10.1063/1.5024105

[Summary of Savonius wind turbine development and future applications for small-scale power generation](#)

*Journal of Renewable and Sustainable Energy* **4**, 042703 (2012); 10.1063/1.4747822

[Mechanical power efficiency of modified turbine blades](#)

*AIP Conference Proceedings* **1801**, 040006 (2017); 10.1063/1.4973095

[Optimization of a vertical axis wind turbine for application in an urban/suburban area](#)

*Journal of Renewable and Sustainable Energy* **9**, 043302 (2017); 10.1063/1.4994574

---

**AIP** | Conference Proceedings

Get **30% off** all  
print proceedings!

Enter Promotion Code **PDF30** at checkout



# Experimental Studies Of Savonius Wind Turbines With Variations Sizes And Fin Numbers Towards Performance

Ilham Satrio Utomo<sup>a)</sup>, Dominicus Danardono Dwi Prija Tjahjana<sup>b)</sup>, Syamsul Hadi<sup>c)</sup>

Mechanical Engineering Department, Faculty of Engineering, Sebelas Maret University, Surakarta 57126, Indonesia

<sup>a)</sup>Corresponding author: [ilhamsatrio0520@gmail.com](mailto:ilhamsatrio0520@gmail.com)

<sup>b)</sup> [ddanardono@staff.uns.ac.id](mailto:ddanardono@staff.uns.ac.id)

<sup>c)</sup> [syamsulhadi@staff.uns.ac.id](mailto:syamsulhadi@staff.uns.ac.id)

**Abstract.** The use of renewable energy in Indonesia is still low. Especially the use of wind energy. Wind turbine Savonius is one turbine that can work with low wind speed. However, Savonius wind turbines still have low efficiency. Therefore it is necessary to modify. Modifications by using the fin are expected to increase the positive drag force by creating a flow that can enter the overlap ratio of the gap. This research was conducted using experimental approach scheme. Parameters generated from the experiment include: power generator, power coefficient, torque coefficient. The experimental data will be collected by variation of fin area, horizontal finning, at wind speed 3 m/s - 4,85 m/s. Experimental results show that with the addition of fin can improve the performance of wind turbine Savonius 11%, and by using the diameter of 115 mm fin is able to provide maximum performance in wind turbine Savonius.

## INTRODUCTION

The use of alternative energy is a topic that began to be widely discussed. This is due to the growing technology that causes people to start looking for new and renewable energy sources to replace conventional energy sources. Wind energy is one of the energy that began to be utilized to generate electricity or convert it into mechanical energy for other purposes. One of the tools used to utilize wind energy is wind turbines.

Wind turbines have the ability to convert mechanical energy into electrical energy with the help of a generator. The most widely used type of turbine is a horizontal axis type wind turbine. Where in its use requires high-speed wind flow and flow parallel to the turbine axis. Since the Indonesian territory has a wind speed that changes with the average wind speed in Indonesia is about 3-6 m/s, with such speed then the suitable turbine is a vertical axis turbine type.

One of the oldest types of VAWT is the Savonius type [1]. This turbine has been widely studied since 1920 to date by many researchers. The workings of VAWT Savonius itself are based on the difference from the drag force that concerns the semicircle surface of the rotor. The sum of the drag forces that affect the rotor is what if the positive value will be able to rotate the turbine shaft. Many of the advantages of the VAWT Savonius wind turbine are like being able to receive wind from every direction, easy and inexpensive in its manufacture, and can rotate at a fairly low angular velocity. However, the standard design of the Savonius-type VAWT still has a low efficiency when compared to other VAWT types [2], [3]

To achieve good efficiency, several modifications have been made including the addition of an end plate, modifications to the geometry and the shape of the blade profile, the addition of the stage number, the use of the valve, and so on [4]. Frika [5] studied experimentally and simulated with the modification of Savonius turbine with multi-stage. Coefficient of power (CP) and coefficient of torque (CT) increases with increasing number of stages. Jeon [1] conducted a study using variations in the size of the end plate area in a twisted wind turbine, the full-plate end plate area resulted in a better 36% cp compared to without the end plate. In a study of kubernus [6] conducting a three-

study turbine blade research with variations of overlap ratio and phase shift angle. The larger Overlap Ratio on a three-stroke turbine blade can help raise the Starting Torque Savonius wind turbine. Overlap Ratio is the inlet of airflow that has been reflected by the side of the blade-blade to pound the next blade. Blackwell [7] in his study reached the conclusion that the optimal value of the overlap ratio is between 10% - 15%. While Alexander and Holownia in his study showed an overlap ratio at 20% - 30% showed good performance. The best-performing Savonius has two blades [8]. 2 blade Savonius provides better performance when compared to 3 blades.

In this research proposal used Turbine Savonius with two blades with the development of the addition of fin (fin) on the blade. The addition of the fin on the blade is expected to help incoming air gap through the overlap ratio. Variations performed are fin area on the blade, the distance between fin and the way of preparation of fin that is horizontal, and overlap ratio. The fin addition is expected to focus the pressure on the blade so that the pressure difference between the blades can be increased. The pressure on both blades affects the net force that occurs in the turbine. Net force is the difference between the positive drag force extracted by the blade facing the wind direction with the negative drag of the blade that has its back to the wind. The greater the positive drag delta value of the turbine, the energy extracted from the wind will be even greater. Thus can improve the efficiency of wind turbines.

## MATERIAL AND METHOD

### Savonius wind rotors

This study uses wind turbine type wind axis wind turbine (VAWT) Savonius, used to convert wind energy into torque on the rotating axis. This Savonius wind turbine with a height of  $H = 400$  mm,  $D = 400$  mm diameter, aspect ratio  $(H / D) = 1$ , and overlap ratio  $(m / D) = 15\%$ , the number of 2 blades, shaft diameter = 12 mm, aluminum plate material = 13 mm. Figure 1. Referring to the geometry of the Savonius wind turbine.

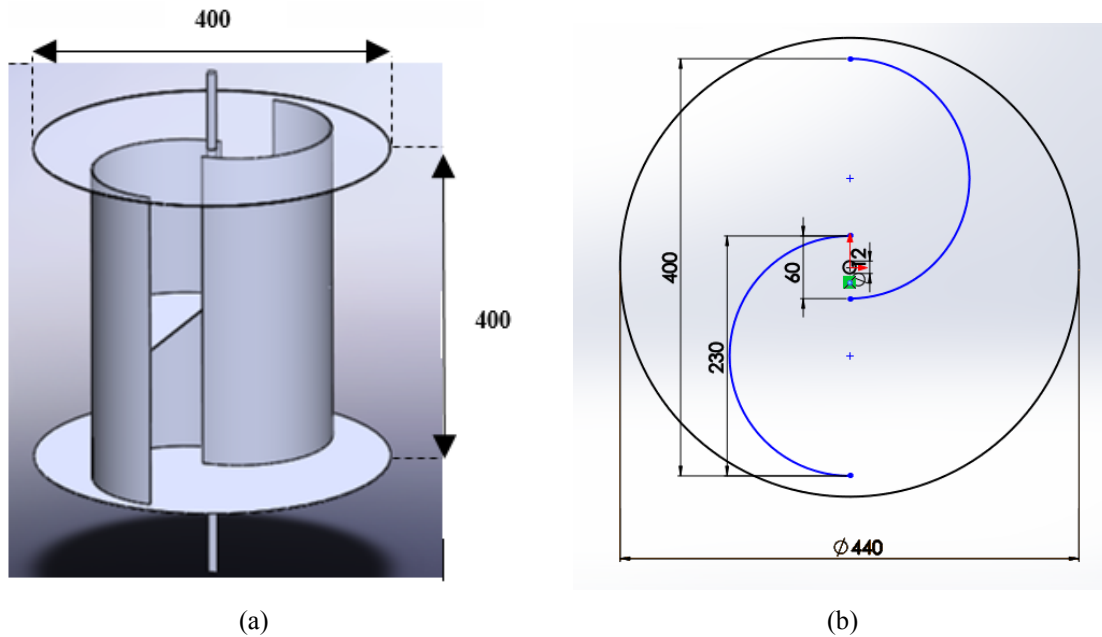

**Figure 1** Savonius wind rotor (a) Geometry Savonius (b)

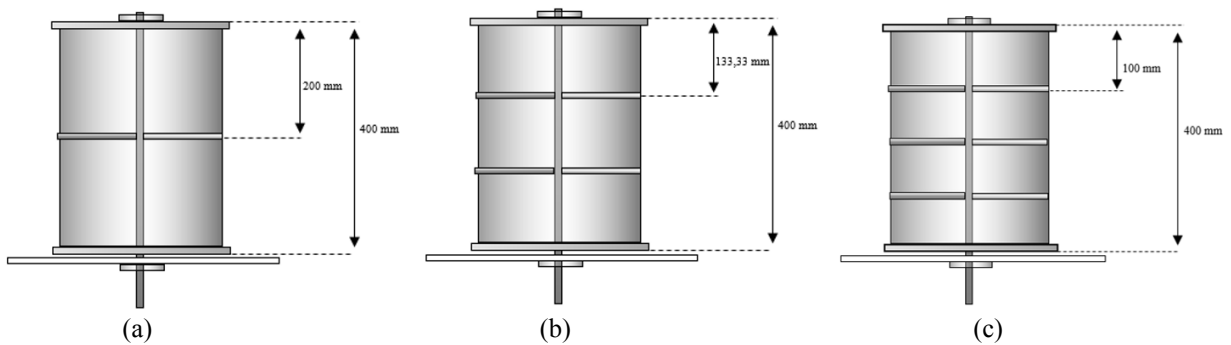

**Figure 2** Savonius Wind Turbine with Fin Variation (a) Savonius geometry with variation 1 fin (b) Savonius geometry with 2 fin (c) Savonius geometry with 3 fin

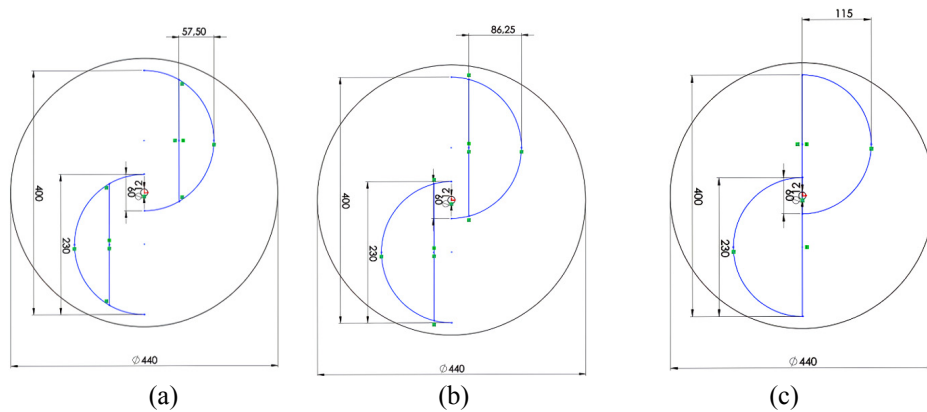

**Figure 3** Savonius Wind Turbine with diameter (a) Variation of fin area with diameter 57.50 mm (b) Variation of fin area with diameter 86.25 mm (c) Variation of fin area with diameter 115 mm

### Experimental Apparatus

The overall design of the wind tunnel is illustrated in Figure 2. The wind tuner consists of fan blower, anemometer, tachometer, generator, and turbine tower. The rated wind speed of the fan is 3.2 m / s - 4.8 m / s

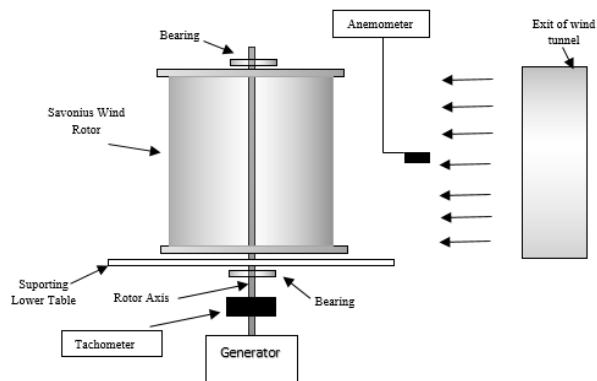

**Figure 4** Schematic view of experimental set-up

Wind speed is measured using an anemometer. An anemometer is used to measure 9 points on the front of the turbine. The tachometer is used to measure the speed of rotation (RPM) of the wind turbine shaft. The tachometer used in this study is a DT2234C + tachometer (Fig.5). The multimeter (Fig.6) is used to calculate the current and voltage generated by the generator. The resulting strong value of AC servo motor current can be calculated by the equation:

$$I = \frac{V}{R} \tag{1}$$

V is the voltage (volt) and R is the resistance (ohm).

After calculating the strong value of the next current can be done data analysis as follows: Power coefficient (Cp), Torque coefficient (Ct), Tip speed ratio ( $\lambda$ )



**Figure 5** Tachometer

**Table 1** Characteristics of the tachometer

Description	DT2234C+
Display	Large 5 digit, 18mm LCD.
Test select	Automatic
Range	2.5 to 99,999 RPM
Resolution	0.1 RPM (from 2.5 to 999.9 RPM) 1 RPM (over 1,000 RPM)
Accuracy	+/- ( 0.05% +1 digit)
Distance	50 to 500mm/ 2 to 20 inch
Memory	Last Value. Max Value. Min RPM
Size	130 x 70 x 29 mm
Weight	160g



**Figure 6** Multimeter

**Table 2** Characteristics of the multimeter

Description	<b>Krisbrow 10037772</b>
Type	Digital Multimeter
Dimension Unit	14.5 X 10.8 X 4.8 CM
AC Earth Voltage	250 V
Accuracy	DC Voltage $\hat{A}\pm(0.5\%+2)$ AC Voltage $\hat{A}\pm(1.2\%+10)$ DC Current $\hat{A}\pm(1\%+2)$ Resistance $\hat{A}\pm(0.8\%+2)$
Resistance	200/2k/20k/200k/2M Ohm
Memory	Last Value. Max Value. Min RPM
Size	130 x 70 x 29 mm
Weight	160g

## RESULTS AND DISCUSSION

### Influence of 1 Fin with variation of fin extents 57.50 mm, 86.25 mm, and 115 mm.

The  $C_p$  and  $C_t$  graphs of the experimental results in the 15% overlap ratio are shown in figures 7. The results show that the coefficient of torque decreases with the increase of TSR. On the other hand the power coefficient increases to a certain TSR. The best performance is shown by a turbine with a fin extension of 115 mm. The fin area with low diameter will cause the wind can not focus maximally on the blade. Using a full-diameter endplate area can increase the drag force in the Savonius wind turbine [1], As shown in Figure 7. Increasing drag diameter fin will improve the performance of the wind turbine Savonius. While the wind coming into the blade will enter the overlap ratio. So as to encourage blade returning blade. By inhibiting the wind on the blade returning blade will reduce the negative drag force that concerns the Savonius wind turbine [9]. Additionally, by adding a device to the blade capable of draining the wind into the overlap ratio can increase the power coefficient [10].

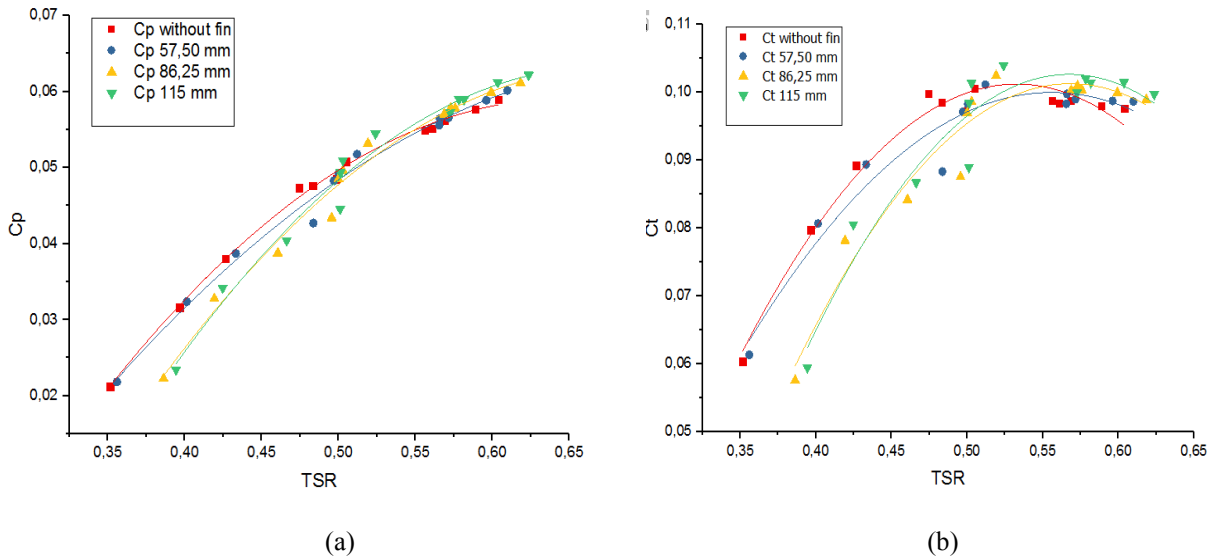

**Figure 7** Graph of  $C_p$  relationship with TSR on fin area variation (a) Graph of  $C_t$  relationship with TSR on fin area variation (b)

### Influence of 2 Fin with variation of fin extent 57,50 mm, 86,25 mm, and 115 mm.

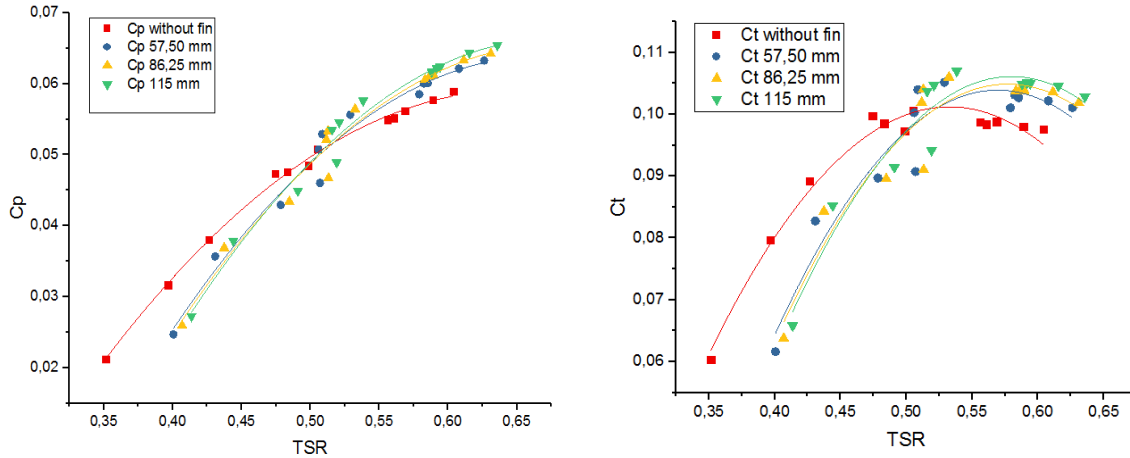
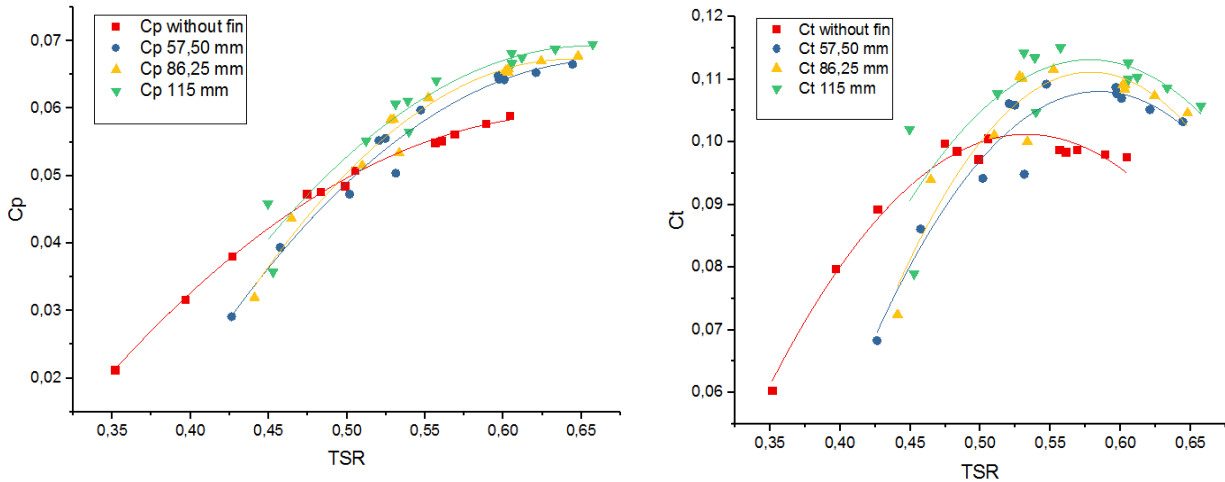

**Figure 8** Graph of Cp relationship with TSR on fin area variation (a) Graph of Ct relationship with TSR on fin area variation (b)

Figures 8 show the experimental results of Cp and Ct graphs over 15% overlap ratio using 2 fin. The results show that the coefficient of torque decreases with increasing TSR. The best performance of 2 fin is shown using a fin diameter of 115 mm. By using a low diameter will cause the wind that is on the blade is not focused maximally. Using end plate area using full diameter can improve the performance of wind turbine Savonius [1]. As shown in Figures 8. With increasing fin diameter on the blade will increase the coefficient of power in the turbine, because the incoming wind will focus on the blade. While the overlap ratio will create a boost that will be about the blade returning blade. By reducing the negative drag force on the blade will add a positive drag force to the Savonius wind turbine [9]. In addition to that, increasing multiple quarters on the blade can add to the wind drag of the Savonius wind turbine and performance, as shown in Figures 8 [10].

### Influence of 3 Fin with variation of fin extent 57,50 mm, 86,25 mm, and 115 mm.

Figure 9 show a graph of experimental results of Cp and Ct with overlap ratio of 15% using 3 fin on the blade. The result shows the coefficient of torque decreases with the increase of TSR. The best performance is shown by using a diameter of 115 mm. This happens because by using a low fin fin causes the wind that is on the blade will not work optimally. Using the maximum endplate area can improve wind turbine performance [1]. As shown in Figures 9 using full diameter fin can increase turbine power efficiency. While using the overlap ratio of 15% by using fin then fin will serve as a wind rectifier enters the overlap ratio and pushes the blade returning blade. By inhibiting the returning blade then this will add a positive drag force to the wind turbine [9]. Increasing fin can add windcrew into the overlap ratio. In addition to that, the addition of the receptors present in the blades can exert maximum wind [10].



**Figure 9** Graph of Cp relationship with TSR on fin area variation (a) Graph of Ct relationship with TSR on fin area variation (b)

## CONCLUSION

The addition of a fin on the Savonius wind turbine is expected to provide a positive drag force that can increase wind turbine efficiency Savonius. From the experiments has been done then it can be taken some conclusions by using 3 fin with diameter of 115 mm can give maximum Cp when compared with without using fin. Cp maximum fin produced 0.069. As the fin area increases, it can help provide maximum drag force on wind turbine variations of Savonius.

## ACKNOWLEDGMENTS

The research is supported by Universitas Sebelas Maret Surakarta through PNPB research grant (PU UNS), T.A. 2017, No: 623/UN27.21/PP/2017

## REFERENCES

- 1 K. S. Jeon, J. I. Jeong, J.-K. Pan, and K.-W. Ryu, "Effects of end plates with various shapes and sizes on helical Savonius wind turbines," *Renew. Energy*, vol. 79, pp. 167–176, 2015.
- 2 M. Mahmood *et al.*, "Vertical axis wind turbine – A review of various configurations and design techniques," *Renew. Sustain. Energy Rev.*, vol. 16, no. 4, pp. 1926–1939, 2012.
- 3 J. Vicente, H. Antonio, and A. Prisco, "A review on the performance of Savonius wind turbines," *Renew. Sustain. Energy Rev.*, vol. 16, no. 5, pp. 3054–3064, 2012.
- 4 J. V. Akwa, G. Alves, and A. P. Petry, "Discussion on the verification of the overlap ratio influence on performance coefficients of a Savonius wind rotor using computational fluid dynamics," vol. 38, pp. 141–149, 2012.
- 5 S. Frikha, Z. Driss, E. Ayadi, Z. Masmoudi, and M. S. Abid, "Numerical and experimental characterization of multi-stage Savonius rotors," *Energy*, vol. 114, pp. 382–404, 2016.
- 6 J. Kumbernuss, J. Chen, H. X. Yang, and L. Lu, "Journal of Wind Engineering Investigation into the relationship of the overlap ratio and shift angle of double stage three bladed vertical axis wind turbine (VAWT)," vol. 108, pp. 57–75, 2012.
- 7 Blackwell BF, Sheldahl RE, Feltz LV. Wind tunnel performance data for two- and three-bucket Savonius rotors. Sandia Laboratories, USA, Sand 76-0131 under act AT/29-11; 1978. p. 789..
- 8 U. K. Saha, S. Thotla, and D. Maity, "Journal of Wind Engineering Optimum design configuration of Savonius rotor through wind tunnel experiments," vol. 96, pp. 1359–1375, 2008.
- 9 M. H. Mohamed, G. Janiga, E. Pap, and D. Thévenin, "Optimization of Savonius turbines using an obstacle shielding the returning blade," *Renew. Energy*, vol. 35, no. 11, pp. 2618–2626, 2010.
- 10 S. Sharma and R. K. Sharma, "Performance improvement of Savonius rotor using multiple quarter blades – A CFD investigation," *Energy Convers. Manag.*, vol. 127, pp. 43–54, 2016.