

See discussions, stats, and author profiles for this publication at: <https://www.researchgate.net/publication/289639250>

Dynamic modeling, simulation and control strategies for 2 MW wind generating systems

Article in *International Review on Modelling and Simulations* · December 2010

CITATION

1

READS

1,457

2 authors:



Lucian MIHET-POPA

Østfold University College

108 PUBLICATIONS **536** CITATIONS

[SEE PROFILE](#)



Voicu Groza

University of Ottawa

261 PUBLICATIONS **1,683** CITATIONS

[SEE PROFILE](#)

Some of the authors of this publication are also working on these related projects:



CSA as Diagnosis Media for incipient faults in Induction Machines [View project](#)



Project of Dr. Prof. Satyendra N. Biswas [View project](#)

DYNAMIC MODELING, SIMULATION and CONTROL STRATEGIES for 2 MW WIND GENERATING SYSTEMS

L. Mihet-Popa¹ and V. Groza²

Abstract – This paper gives an overview of the control strategies for large wind turbines using induction generators. Also, the paper describes dynamic modeling and simulation results of a two power generating systems: active-stall constant-speed wind turbine with cage-rotor induction machine connected to the grid through a soft-starter and a pitch-controlled variable-speed wind turbine using wound-rotor induction machine with the stator windings directly connected to the grid and with the rotor windings connected to a back-to-back partial scale power converter. To evaluate the performance for both wind turbine concepts, a set of simulations are performed for wind gusts at an average wind speed higher than the rated value. The models are implemented in the power system simulation tool DIgSILENT Power Factory, which provides an extensive library for grid components and a dynamic simulation language for modeling of each wind turbine component.

Keywords: active stall control, cage-rotor & doubly-fed induction machine, pitch angle control, rotor efficiency, wind gusts, wind turbines;

Nomenclature: C_p -power coefficient of the wind turbine; $dP/d\theta$ - aerodynamic sensitivity; f_s -supply frequency; i_s -stator current; i_r -rotor current; $L_{s,r}$ - inductance, n - motor speed; P -active power, P_{aero} -aerodynamic power, P_{err} -error signal, P_m -measured generator power, P_{ref} -reference power, PWM-pulse width modulation, R - radius of wind turbine rotor; Q -reactive power, s -slip; T -transformer; u_{eq} -equivalent wind speed, v_{av} -average wind speed, V_s -stator voltage of the machine; θ_{pitch} -pitch angle of the blades, θ -actual pitch angle, θ_{e2} -error signal, θ_{dp} -pitch angle demand, λ -tip speed ratio, θ_{ref} -reference value of the pitch angle, θ_{max} -upper limit of the pitch angle, ω_{rot} -rotor speed of wind turbine.

I. Introduction

The wind energy industry has developed rapidly through the last 20 years. The development has been concentrated on grid connected wind turbines (wind farms) and their control strategies [1-2].

To study performance of the wind generating system in different modes of operation a dynamic model should be developed [3-17].

The aim of a wind turbine controller is to ensure that the wind turbine is able to produce energy at the lowest possible cost (minimum price per kWh). The cost of wind-generated electricity has declined about 90 % over the last 20 years [3].

Today, large new wind farms for IEC Wind class I and II sites generate electricity at a cost of 0.04 to 0.06 US dollars / kWh. That places the cost of power from the most efficient wind farms in a range that is competitive with that of electricity from new conventional power plants [3, 17].

Conventional stall wind turbines are equipped with cage rotor induction generators, in which the speed is almost constant, while the variable speed and variable

pitch wind turbines use doubly-fed induction generators or synchronous generators in connection with a power converter (partial rate or full rate). The variable speed wind turbine has a more complicated electrical system than the fixed-speed wind turbine, but it is able to achieve maximum power coefficient over a wide range of wind speeds and about 5-10 % gain in the energy capture can be obtained [1-2, 14-20].

The aim of this paper is to give an overview regarding the state of the art in wind turbines control strategies and to evaluate their dynamic performance during sudden changes in wind speed. Also, the article describes dynamic modelling and simulation results for two power generating systems based on induction generators.

II. Control Strategies for Wind Turbines

Wind turbines are designed to produce electrical energy as cheaply as possible. Wind turbines are therefore generally designed so that they yield maximum output power at wind speeds around (12-15) meters per second [1-2, 15-17, 19-20].

In case of stronger winds it is necessary to waste a part of the excess energy of the wind in order to avoid damaging the wind turbine. All wind turbines are therefore designed with some sort of power. There are two different ways of doing this safely on modern wind turbines: pitch control and active stall control, as will be described as follows control [14-17, 20].

II.I. Pitch-Controlled Wind Turbines

On a pitch controlled wind turbine the electronic controller checks the output power of the turbine several times per second. When the output power becomes too high, it sends an order to the blade pitch mechanism which immediately pitches (turns) the rotor blades slightly out of the wind. Conversely, the blades are turned back into the wind whenever the wind drops again. The rotor blades thus have to be able to turn around their longitudinal axis (to pitch). During normal operation the blades will pitch a fraction of a degree at a time - and the rotor will be turning at the same time. Designing a pitch-controlled wind turbine requires some clever engineering to make sure that the rotor blades pitch exactly the amount required. The pitch mechanism is usually operated using hydraulics or electric stepper motors. As with pitch control it is largely an economic question whether it is worthwhile to pay for the added complexity of the machine, when the blade pitch mechanism is added [14-17, 20].

II.II. Stall-Controlled Wind Turbines

Stall controlled or passive stall controlled wind turbines have the rotor blades bolted onto the hub at a fixed angle. The geometry of the rotor blade profile however has been aerodynamically designed to ensure that the moment when the wind speed becomes too high; it creates turbulence on the side of the rotor blade which is not facing the wind. This stall prevents the lifting force of the rotor blade from acting on the rotor. As the actual wind speed in the area increases, the angle of attack of the rotor blade will increase, until at some point it starts to stall. If you look closely at a rotor blade for a stall controlled wind turbine you will notice that the blade is twisted slightly as you move along its longitudinal axis. This is partly done in order to ensure that the rotor blade stalls gradually rather than abruptly when the wind speed reaches its critical value. The basic advantage of stall control is that one avoids moving parts in the rotor itself, and a complex control system. A normal passive-stall controlled wind turbine will usually have a drop in the electrical power output for higher wind speeds, as the rotor blades go into deeper stall. On the other hand, stall control represents a very complex aerodynamic design problem, and related design challenges in the structural dynamics of the whole wind turbine, e.g. to avoid stall-induced vibrations [14-17, 20].

II.III. Active Stall-Controlled Wind Turbines

An increasing number of larger wind turbines (1 MW and more) are developed with an active stall power control mechanism. Technically the active stall turbines resemble pitch-controlled turbines, since they have pitch able blades. In order to get a reasonably large torque (turning force) at low wind speeds, the wind turbines will usually be programmed to pitch their blades much like a pitch controlled wind turbine at low wind speeds. Often they use only a few fixed steps depending upon the wind speed. When the turbine reaches its rated power, however, it will notice an important difference from the pitch controlled wind turbines: If the generator is about to be overloaded, the turbine will pitch its blades in the opposite direction from what a pitch-controlled wind turbine does. In other words, it will increase the angle of attack of the rotor blades in order to make the blades go into a deeper stall, thus wasting the excess energy in the wind. One of the advantages of active stall is that one can control the active power more accurately than with passive stall, so as to avoid overshooting the rated power of the turbine at the beginning of a gust of wind. Another advantage is that the wind generator can be run almost exactly at the rated power of the machine at all high wind speeds.

II.IV. Transmission System Model

The output power of wind turbines varies with wind speed, but is not proportional to it, as the energy that the wind contains increases with the cube of the wind speed. At low wind speeds (1-3 m/s), wind turbines are shut down, as they would be able to generate little or no power (Fig. 2). Wind turbines only start-up at wind speeds between 2.5 and 5 m/s, known as the “cut-in” wind speed. “Nominal” or “rated” wind speed, at which nominal output power is reached, is normally between 12 and 15 m/s. The precise value depends on the ratio of generator capacity to rotor surface area, and is a design variable. Finally, any wind turbine has a “cut-out wind speed”: this is the wind speed at which the turbine is shut down to avoid structural overload. Its value is around 25 m/s for IEC Wind class I and II turbines [17]. For IEC Wind Class III turbines, which generate maximum output power at lower wind speeds, the cut-out value is in the range of 17-20 m/s. Wind turbines are shut down if the 10-minute average of the wind speed is above this design value. Below nominal wind speed, the aim is to maximize rotor efficiency (Fig. 2). The rotor efficiency depends on the ratio of the rotor blade tip speed and wind speed, known as the “tip speed ratio” (λ), described by:

$$\lambda = \omega_{rot} \cdot R / u_{eq} \quad (1)$$

The tip speed ratio of a fixed speed wind turbine cannot be controlled, as the rotor speed (and thus the blade tip speed) is fixed. Nevertheless, the tip speed

ratio varies with wind speed, and thus reaches the optimum value at one wind speed only in case of fixed speed designs (or at two speeds if the wind turbine can operate at two different, but constant, rotor speeds). With a variable speed wind turbine, the tip speed ratio varies, and depends both on wind speed and rotor speed. For maximum rotor efficiency, the tip speed ratio must be maintained at the value that corresponds to optimum rotor efficiency (usually 6-9) at all times. This is achieved by controlling the rotor speed accordingly. The higher aerodynamic efficiency that is thus achieved explains why a variable speed turbine generates more energy for the same wind speed regime.

At wind speeds below nominal, the aim is to extract energy from the wind as efficiently as possible; however, this ceases to apply above nominal wind speed, as this would overload the generator and/or the converter system. Above nominal wind speed, therefore, the mechanical power extracted from the wind must remain constant. To achieve this, the aerodynamic rotor efficiency must be reduced when the wind speed increases, as can also be seen in Fig. 2.

In a stall controlled wind turbine, the blades are designed such that the rotor efficiency “collapses” at high wind speeds. Due to the blade design, this behavior is intrinsic, and no active control systems are required to achieve the aerodynamic efficiency reduction. In a pitch controlled wind turbine, the blades are gradually turned out of the wind, so the wind impact angle changes and the aerodynamic efficiency is reduced. In this case active stall control is applied, by means of hydraulics or an electric drive system. The input variable for the pitch controller is the rotor speed, as it is depicted in Fig. 1. The higher the rotor speed, the more the blades are turned out of the wind. The blades are turned back into the wind when the rotor speed falls. In general, fixed speed turbines use stall control for technical reasons, while variable speed turbines are usually equipped with pitch control [17, 20].

A relatively recent innovation is the active-stall concept. This is similar to normal stall power limitation, except that the whole blade can be rotated backwards (in the opposite direction as is the case with pitch control) by a few (3-5) degrees at the nominal speed range in order to give better rotor control. The application of this concept is more or less restricted to fixed speed turbines.

Typical active-stall representatives are the Danish manufacturers Bonus (1 MW and over) and NEG Micon (now Vestas) (1.5, 2 MW and over) [14-17].

The difference from active pitch control is not only that the range of blade angle variation is less, but also that the direction of the variation is opposite.

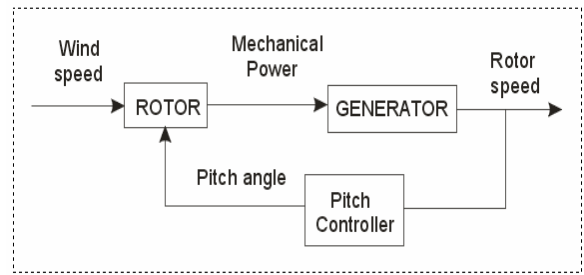

Fig. 1. Rotor speed control principle for wind speeds above nominal.

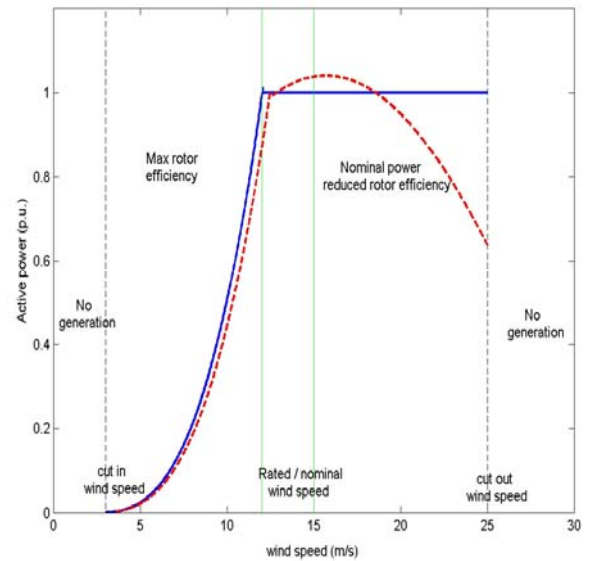

Fig. 2. Typical power curves and operation areas of a stall (dashed line) and pitch controlled (solid line) wind turbines

III. Active Stall Wind Turbine using Cage-Rotor Induction Generators

A common control concept for new megawatt-size wind turbines/wind farms without power electronic converters is the active stall regulation. An active stall wind turbine is a stall controlled turbine with variable pitch angle. At high wind speeds, the pitch angle is adjusted to obtain the desired rated power level. When connecting the wind generator to the grid, the pitch angle is also adjusted in order to obtain a smooth connection. The use of active stall control also facilitates the emergency stopping of the turbine.

The control strategy called active-stall constant-speed involves the combined interaction between wind model, pitch control and the aerodynamics of the wind turbine, as can be seen in Fig. 3 [1, 15-17].

The blade angle control block models the active-stall control of the wind turbine based on the measured power and the set point [15-17].

The most used electrical generator of an active-stall constant-speed turbine is a cage rotor induction

generator connected to the grid through a soft-starter, as can be seen in Fig. 3.

A clear difference between stall and active stall controlled wind turbines is a pitch actuator system for variable pitch angles, as can be seen in Fig. 4, which allows the stall effect to be controlled.

The model of the pitch control system is based on the measured generator power and the aerodynamic power of wind turbine as a function of measured wind speed at different pitch angles.

The measured power is compared with its reference and the error signal multiplied by pitch angle of power control is sent to the PI-controller producing the pitch angle demand, which together with maximum pitch angle-upper limit is sent to the pitch limitation non-

linear block producing the reference value of the pitch angle.

The reference value is in the range between the optimised pitch and the maximal pitch angle ($\theta_{max}=90^0$). The maximum value is defined as a function of average wind speed. The reference value is, further, compared to the actual pitch angle and the error signal is corrected by the pitch hydraulics.

This control strategy takes its origin in the power coefficient curves $C_p(\theta, u)$, typical for a 2 MW constant speed wind turbine, as it is depicted in Fig. 5.

C_p represents the rotor (aerodynamic) efficiency of the wind turbine and depends on the pitch angle and on the tip speed ratio. In order to achieve maximum power yield for each wind speed the maximal C_p and the corresponding θ has to be found.

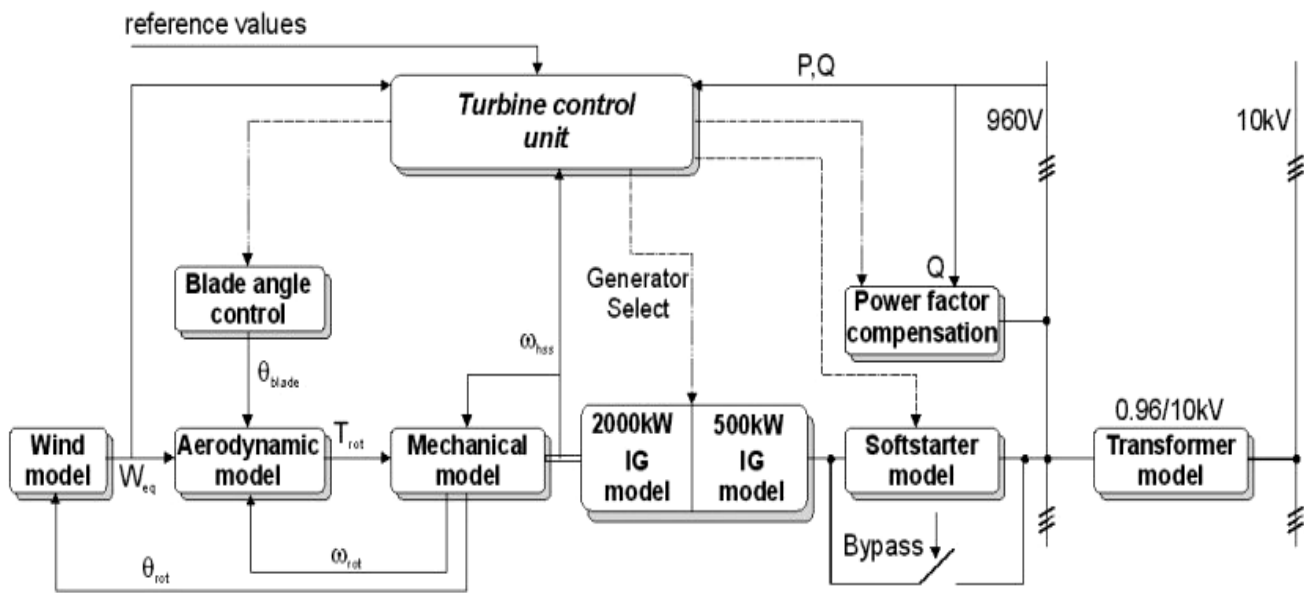

Fig. 3. Block diagram of an active stall controlled wind turbine with constant speed using a cage-rotor induction generator [17].

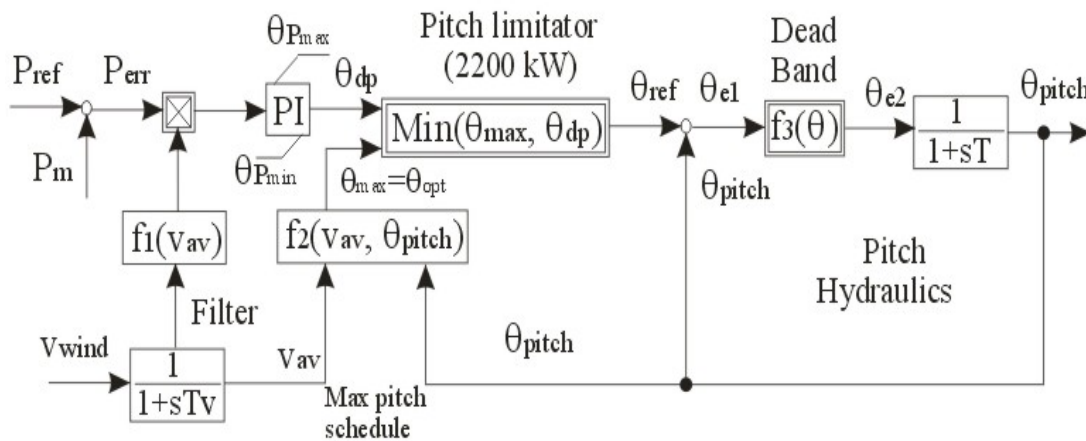

Fig. 4. The block diagram of blade pitch angle control system [20].

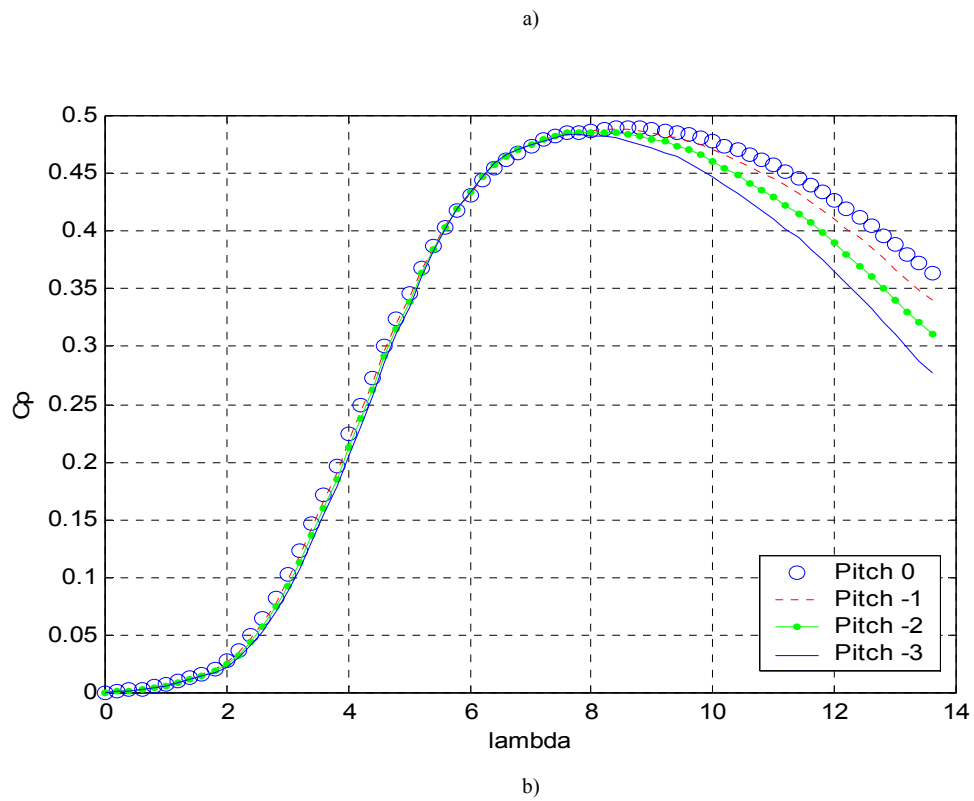

Fig. 5. Power coefficient (C_p) of a 2MW wind turbine versus wind speed (a), and the tip speed ratio (λ), (b) at different pitch angles.

The aerodynamic power is calculated according to:

$$P_{aero} = \frac{1}{2} \rho \pi R^2 u_{eq}^3 C_p(\lambda, \theta_{pitch}) \quad (2)$$

In order to achieve maximum power yield for each wind speed the maximal C_p and the corresponding θ has to be found. In fact, the control strategy is characterised by two terms: the optimal region and the power limiting region. In the optimal region (between start-up wind speed and nominal wind speed), the output power is designed to fulfil the criterion of maximal C_p , which corresponds to the optimal energy capture, by keeping the tip speed ration constant. In the power limiting region (between nominal wind speed and cut-out wind speed), the output power is kept constant, while the wind turbine will pitch the blades a few degrees every time when the wind changes in order to keep the rotor blades at the optimum angle. When the wind turbine reaches its rated power, and the generator is about to be overloaded, the turbine will pitch its blades in the opposite direction. In this way, it will increase the angle of attack of the rotor blades in order to make the blades go into a deeper stall, thus wasting the excess energy in the wind [20].

IV. Variable-Speed Wind Turbine using DFIG

Figure 7 presents the control system of a variable-speed wind turbine with DFIG. The control system contains two control levels: the DFIG control level, with a fast dynamic response, and the wind turbine control level, with a slow dynamic response.

A doubly-fed induction generator (DFIG) is a standard wound-rotor induction machine with the stator windings directly connected to the grid and with the rotor windings connected to a back-to-back partial scale frequency converter. The frequency converter consists of two independent converters connected to a common dc-bus. The behaviour of the generator is governed by these converters and their controllers.

The DFIG control level contains two controllers: the rotor side converter controller, which controls independently the active and reactive power on the grid and the grid side converter controller, which controls the DC link voltage and maintains unity power factor. The rotor side converter controller contains an independent cascade control branches, one for active power control and the other for reactive power control, controlled indirectly by controlling the impressed rotor currents [16-23]. The DFIG model is expressed in the rotor reference frame and the rotor side converter controller is expressed in the stator flux reference frame. The control of rotor side converter is based on the stator flux oriented rotor current control approach, where the rotor current is split into a parallel and orthogonal component to the stator flux. It contains two control loops in cascade: a slower (outer) power

control loop and a fast (inner) rotor current control loop [20].

The control of the grid side converter also contains two control loops in cascade, a slower (outer) dc-voltage control loop, which regulates the dc link voltage to a predefined value, and a fast (inner) converter current control, which regulates the converter current to the reference value specified by the slower dc-voltage controller [17, 20].

Similarly to the rotor side converter, the grid side converter is current regulated. The dc-voltage and the reactive power are controlled indirectly by controlling the grid side converter current.

The wind turbine control provides reference signals both to the pitch system of the blades and to the DFIG control level. It contains two controllers: speed controller, which controls the generator speed at high wind speeds and maximum power tracking controller, which generates the active power reference signal for the active power control loop. This reference signal is determined from the electrical power versus generator speed characteristic (Fig. 6), taken from a look-up table. This characteristic is based on aerodynamic data of the wind turbine's rotor and its points correspond to the maximum aerodynamic efficiency. Up to 8.5 m/s with a tip speed ratio of around 8.7 (optimum), the rotor speed is proportional to the wind speed (lower part of the curve up to 800 kW/1500 rpm-Fig. 6). From 8.5 m/s to 12 m/s (rated) the rotor speed is controlled until the rated power of 2 MW at 1580 rpm is reached. If the turbine accelerates to above 1580 rpm, due to the wind speed above rated value, the generator power is kept constant at the rated value (2 MW) by the power limitation controller, while the speed controller it takes no action (there is no longer any control of the generator speed). Both the speed controller and the maximum power-tracking controller are active in the power limitation strategy, while only maximum power tracking controller is active in the optimisation power strategy.

Figure 8 shows the speed controller, the maximum power tracking one and the rotor side and grid side converter controllers. All these controllers, except maximum power tracking controller, contains PI-controllers with anti-windup. Both the speed controller and the maximum power tracking have as input the filtered measured generator speed. The generator speed is measured and then a low-pass filter is used. The pitch angle controller is also developed, as a part of the power controller in order to compensate the non-linear aerodynamic characteristics. The error between the filtered measured generator speed and the rated value is sent to the PI speed controller. The output of this controller is used as reference pitch signal to the pitch system.

The reference is compared to the actual pitch angle and then the error is corrected by the servomechanism, as

can also be seen in Fig. 8. Assuming that the dynamic behaviour of the speed controller can be approximated with a second order system behaviour, the parameter design of the PI speed controller can be based on the transient response analysis. The parameters of the PI

speed controller has been directly determined based on design parameters (damping ratio and natural frequency) while the proportional gain has a proportional variation with the aerodynamic sensitivity $dP/d\theta$.

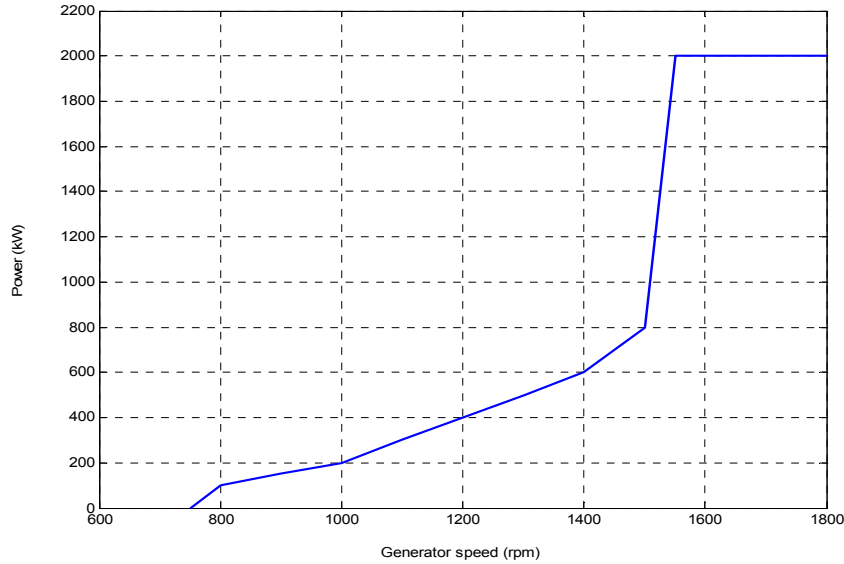

Fig. 6. Electrical power versus generator speed characteristic used in the maximum power tracking controller.

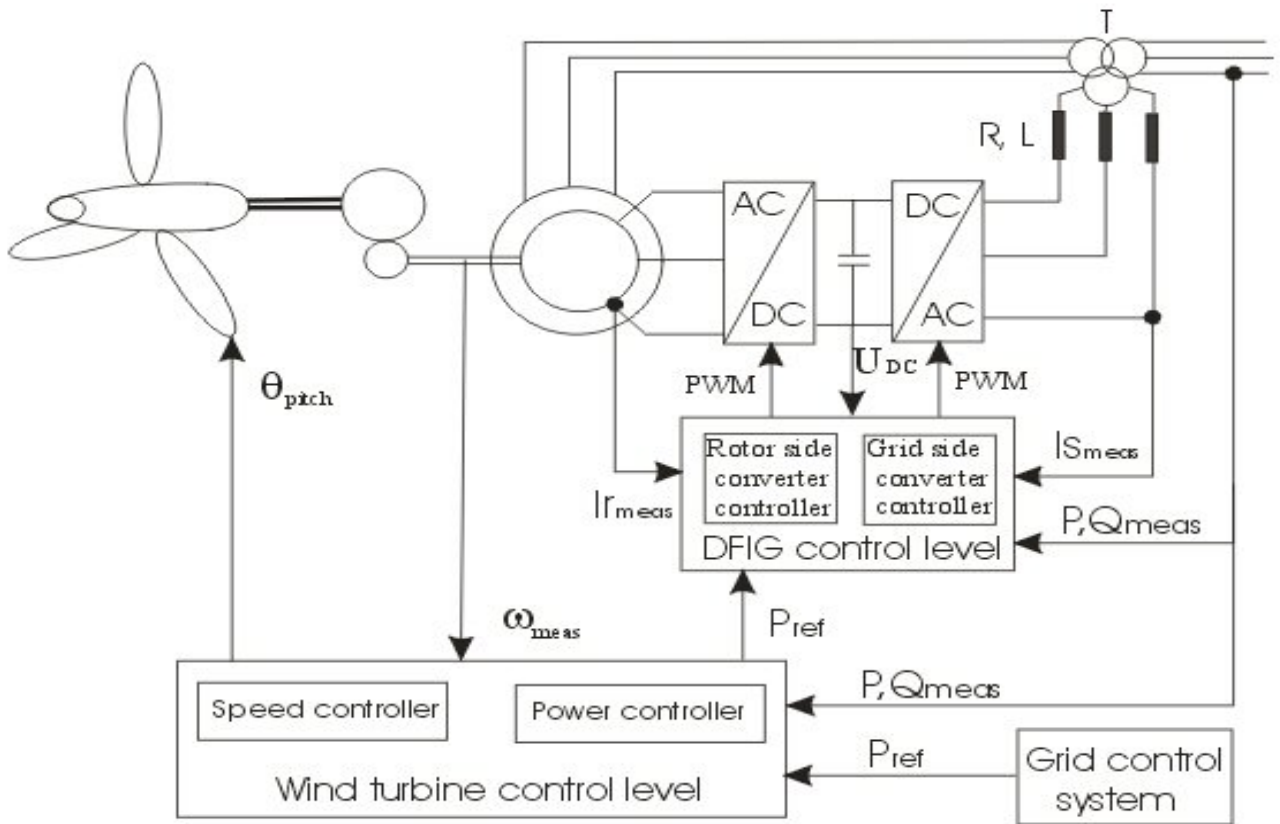

Fig. 7. The control system of a variable-speed wind turbine with DFIG fed by a back-to-back VSI.

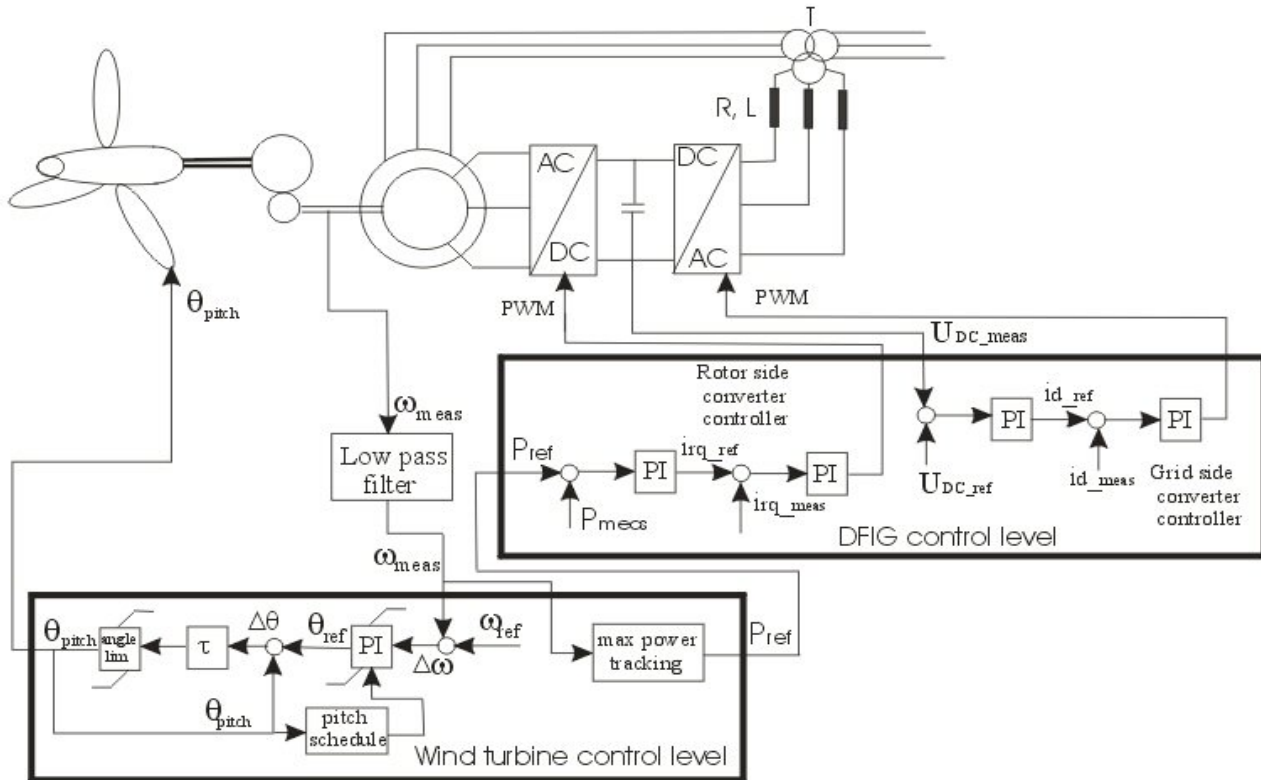

Fig. 8. An overview of the variable-speed wind turbine control strategy.

V. Simulation Results during Heavy Transients

To evaluate the performance of both wind turbine control systems, presented before, a set of simulations are performed using a power system analysis software-DIGSILENT Power Factory.

Both Fig. 9 and Fig. 10 show how a 2 MW wind turbine, with constant speed (Fig. 10) and variable speed (Fig. 9), works during different operation conditions, such as sudden changes in wind speed (wind gusts) with a turbulence intensity of 12 %, at high wind speed.

Figure 9 presents the simulation results of 2 MW variable speed wind turbine that works at a mean wind speed higher than rated one (16 m/s > 12 m/s) corresponding to the power limitation strategy, in which both the speed controller and the power limitation controller are active.

The power limitation controller sets the blade angle to keep the rated power, while the speed controller permits a dynamic variation of the generator speed, in a predefined speed range (in the speed range allowed by the size of the power converter), in order to avoid mechanical stress in the gearbox and the rotor shaft.

To illustrate the elasticity of the variable speed DFIG wind turbine and to test the power controller

performance, some wind gusts of 6 m/s up and down, are introduced in wind speed at each 150 seconds (at 150 s, 300 s and 450 s).

For instance, at $t=150$ s the mean wind speed suddenly reaches from 16 m/s to 22 m/s. In the same time the generator speed and the electrical power increases too. The power limitation control loop is strong and fast and the generator speed follows very well the generator speed reference in order to be able to absorb the maximum energy from the wind.

The pitch controller also reacts modifying the pitch angle, while the wind gusts are absorbed as variation in the generator speed, as can also be seen in Fig. 9.

The rotational speed of the wind turbine rotor is thus allowed to increase storing energy into the wind turbine's inertia.

The control strategy of active stall constant speed wind turbine contains three modes of operation: acceleration control (speed control), power control (power limiting region) and direct pitch control (blade angle control).

The acceleration and pitch control modes are used during start-up, shut down and emergency conditions, while the power control mode is only used during normal operations.

In Fig. 10 the 2 MW induction generator was connected to the grid through a soft-starter (in order to reduce the transient current), at $t=73$ seconds and then the soft-starter was by-passed at $t=77$ seconds.

In the same time the power factor compensation unit started to work using capacitor switching, as a function of average value of measured reactive power.

The mean wind speed was 12 m/s. At $t=100$ seconds the mean wind speed was modified to 18 (m/s) and at $t=170$ seconds mean wind speed was modified again at 11 (m/s) to simulate sudden changes in wind speed and to test the system performance and implemented control strategy. The active and reactive powers have been able to follow these changes in all situations. It is concluded that the wind turbine absorbed the transients very fast and the control strategy offers a good stability of the system during transition of dynamic changes.

DISCUSSION AND CONCLUSION

The paper describes and investigates two control strategies applied for a 2 MW wind generating system widely presented in the literature: active-stall constant-speed wind turbine with cage-rotor induction generator and pitch controlled variable-speed wind turbine with doubly-fed induction generator. For both these two concepts, control strategies are developed and implemented in the power system simulation tool DIGSILENT Power Factory. Different scenarios are simulated to assess the performance of the machine controller and of the overall control of wind turbine, too.

The state of the art of wind turbines seen from electrical point of view includes old and new potential concepts of generators and power electronics based on technical aspects and market trends. Several generic types of generator are possible candidates in wind turbines. The cage rotor induction generator has been frequently applied commercially. The most dominating type, especially in the last ten years, is the induction generator with wound rotor, while the third is the current excited synchronous generator.

A large number of alternative wind turbine designs exist but the state of the art wind turbine may be summarized as a 3-bladed upwind turbine using active-stall control with constant-speed using cage rotor induction generator or pitch control combined with variable-speed using DFIG.

Active-stall constant-speed combines the advantages of passive stall, namely simplicity due to the absence of a pitch mechanism, with the advantages of pitch control, namely controllability.

Simulation results of a 2 MW active-stall constant-speed wind turbine had shown a good stability of the system during normal operation and also during transition of dynamic changes in wind speed.

The overall control of the variable-speed pitch-controlled wind turbine with DFIG has as goal to track the optimum operation point, to limit the power in the case of high wind speeds and to control the reactive

power interchanged between the wind turbine generator and the grid.

The control strategy contains two control levels: DFIG control level (control of active and reactive power using vector control approach) and wind turbine control level (speed controller and power limitation controller).

The simulation results showed that the implemented control strategy for a 2 MW variable-speed pitch-controlled wind turbine is able to control efficiently the DFIG parameters during normal operation and during sudden changes in wind speed.

An important difference between an active-stall controlled wind turbine and a pitch-controlled wind turbine, when they reach rated power, is that the active-stall wind turbine pitches the blades in the opposite direction (negative direction) from what a pitch-controlled wind turbine does.

Both wind turbine control strategies implemented are an important step towards the long term objective of developing tools for study and improvement of the dynamic interaction between wind turbines and power systems.

One future research step is to investigate and enhance the controller's capabilities to handle grid faults. Another interesting issue is to explore the present controllers in the design of a whole wind farm and the connection of the wind farm at different types of grid and storage systems.

References

Journal Papers:

- [1] L. Mihet-Popa, F. Blaabjerg and I. Boldea: *Wind Turbine Generator Modeling and Simulation where Rotational Speed is the Controlled Variable*, IEEE-IAS Transactions on Energy Conversion, January / February 2004, Vol. 40, No. 1, pp. 3-10.
- [2] L. Mihet-Popa, O. Proștean and I. Szeidert, *The soft-starters modeling, simulations and control implementation for 2 MW constant-speed wind turbines*, The International Review of Electrical Engineering – IREE, Vol. 3, No. 1, January-February 2008, pp. 129-135, ISSN: 1827-6660.
- [3] Saifur Rahman, Green Power. What is it and where can we find it?, IEEE power & energy magazine, January/February 2003, pp. 30-37.
- [4] Castello, J.; Garcia-Gil, R.; Espi, J. M.; Gonzalez, S. A., *Dynamic Modeling, Simulation and Control of the Power Conditioning System for a Variable-Speed Wind-Turbine*, International Review of Modelling and Simulations-IREMOS, Vol. 3, No. 1, Jan-Feb. 2008.
- [5] A. I. Estanesqueiro, *A dynamic Wind Generation Model for Power Systems Studies*, IEEE Transaction on Power Systems, Vol. 22, pp. 920-928, 2007.
- [6] Seul-Ki Kim; Jin-Hong Jeon; Chang-Hee Cho; Jong-Bo Ahn; Sae-Hyuk Kwon, *Dynamic Modeling and Control of a Grid-Connected Hybrid Generation System with Versatile Power Transfer*, IEEE Transaction on Industrial Electronics, Vol. 55, Issue 4, pp. 1677-1688, 2008.
- [7] T. Petru and T. Thiringer, *Modeling of wind turbines for power system studies*, IEEE Transaction on Power Systems, Vol. 17, 2002.
- [8] Kamalzadeh, Abdulrahim; Radan, Ahmad, *Direct Power Control of Doubly-Fed Induction Generators Using an Analytical*

- Optimized Switching Table*, International Review of Modelling and Simulations-IREMOS, Vol. 5, No. 1, pp. 70-82, Jan-Feb. 2010;
- [9] A. Abeni, H. Nikkhajoei, *Dynamic model and control of a wind-turbine generator with energy storage*, International Journal of Renewable Power Generation, Vol. 5, Issue 1, pp. 67-73, 2010, ISSN 1752-1416;
- [10] Lie Xu, Yi Wang, *Dynamic modeling and control of DFIG-Based Wind Turbines under unbalanced network conditions*, IEEE Transactions on Power Systems, Vol. 22, Issue 1, February 2007, pp. 314-320, ISSN 0885-8950;
- [11] J.B. Ekanayake, L. Holdsworth, X.G. Wu and N. Jenkins, *Dynamic modelling of doubly fed induction generator wind turbines*, IEEE Transactions on Power Systems, Vol. 18, 2003, pp. 803-809, ISSN 0885-8950;
- [12] Jun Yao, Hui Li, Yong Liao, Zhe Chen, *An improved control strategy of limiting the dc-link voltage fluctuation for a doubly fed induction wind generator*, IEEE Transaction on Power Electronics, Vol. 32, Issue 3, pp. 1205-1213, May 2008;
- [13] Rajib Datta and V.T. Ranganathan, "Direct Power Control of Grid-Connected Wound Rotor Induction Machine without Rotor Position Sensors", IEEE Transactions on Power Electronics, Vol. 16, No. 3, May 2001, pp. 390-399.
- Books:
- [14] Siegfried Heier, *Wind energy conversion systems*, book, John Wiley & Sons Inc., New York, 1998.
- [15] L.H. Hansen, L. Helle, F. Blaabjerg, E. Ritchie, S. Munk-Nielsen, H. Bidner, P. Sorensen and B. Bak-Jensen, *Conceptual Survey of Generators and Power Electronics for Wind Turbines*, Riso-R-1205 (EN), December 2001.
- [16] H. M. Hansen, A.D. Hansen, T.J. Larsen, S. Oye, P. Sorensen and P. Fuglsang, *Control design for a pitch-regulated variable speed wind turbine*, Riso National Laboratory-Riso-R-1500 (EN), Roskilde-Denmark, January 2005.
- [17] Lucian Mihet-Popa, *Wind Turbines using Induction Generators connected to the Grid*, POLITEHNICA University of Timisoara, Romania, December 2007, ISBN 978-973-625-533-5;
- [18] Ion Boldea, *Variable Speed Generators*, CRC Taylor and Francis Group, US 2006, ISBN 0-8493-5715-2.
- Proceedings Papers:
- [19] L. Mihet-Popa and J.M. Pacas, "Active stall constant speed wind turbine during transient grid fault events and sudden changes in wind speed", Proceedings of PCIM 2005, Nuremberg-Germany, 7-9 June, pp. 646-652.
- [20] L. Mihet-Popa and I. Boldea, "Dynamics of control strategies for wind turbine applications", Proceedings of the 10th International Conference on Optimisation of Electrical and Electronic Equipment, OPTIM 2006, May 18-19, Poiana Brasov, Vol. 2, pp. 199-206;
- [21] T. Aboul-Seoud, J. Jatskevich, "Dynamic modeling of induction motor loads for transient voltage stability studies", Proceedings of Electric Power Conference-EPEC 2008, 6-7 October, Vancouver-Canada, ISBN 978-1-4244-2894-6;
- [22] M.B.C. Salles, K. Hameyer, J.R. Cardoso, W. Freitas, "Dynamic Analysis of Wind Turbines Considering New Grid Code Requirements", International Conference on Electrical Machines-ICEM 2008, 6-9 September, Vilamoura, ISBN 978-1-4244-1735-3;
- [23] R. Pena, J.C. Clare, G.M. Asher, "Doubly Fed Induction Generator using Back-to-Back PWM Converters and its Application to Variable Speed Wind Energy Generation", 1996, IEE Proceedings on Electrical Power Applications, Vol. 143, No. 3, pp. 231-241.

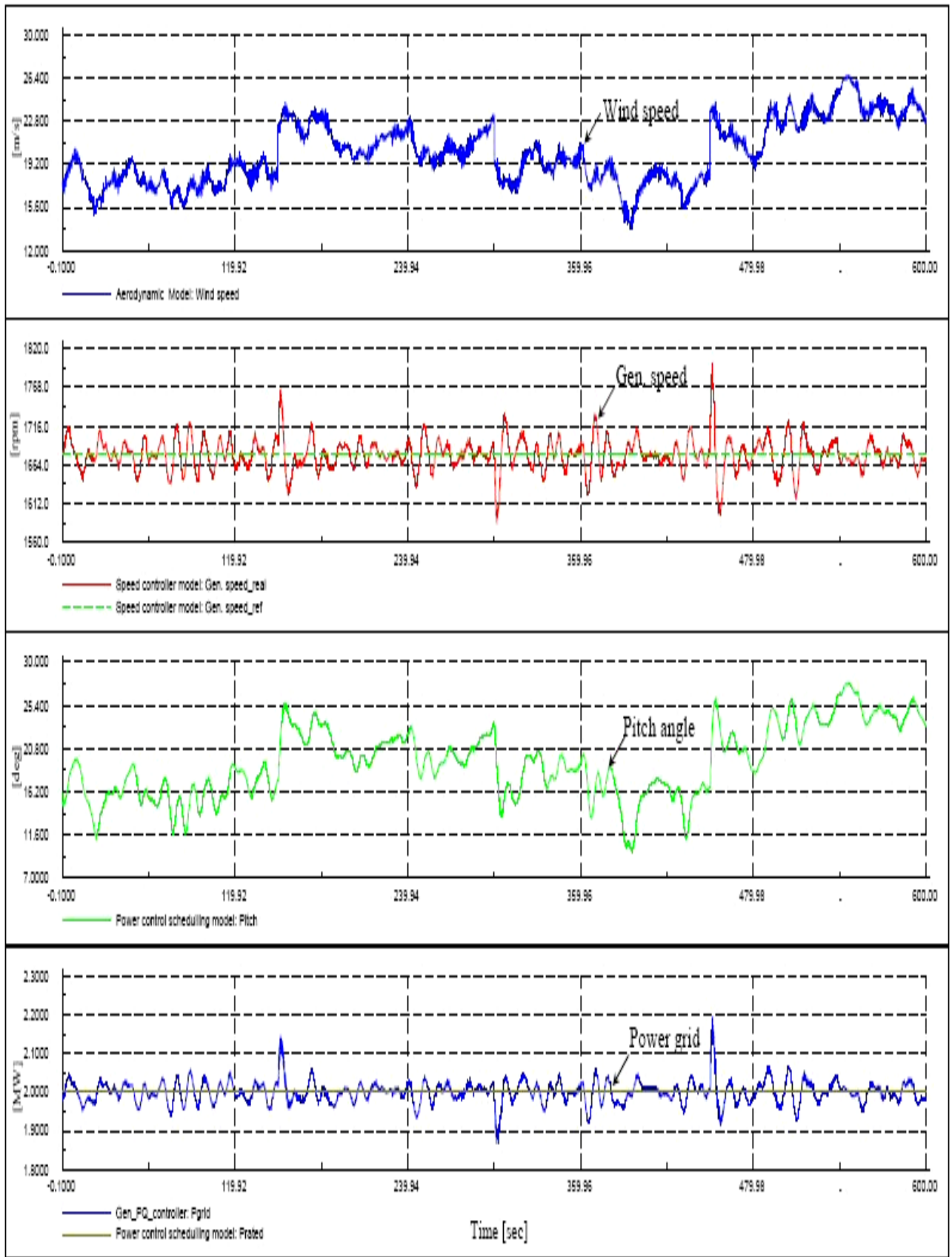

Fig. 9. Simulation results during sudden changes in wind speed for a 2MW pitch controlled variable-speed wind turbine using DFIG.

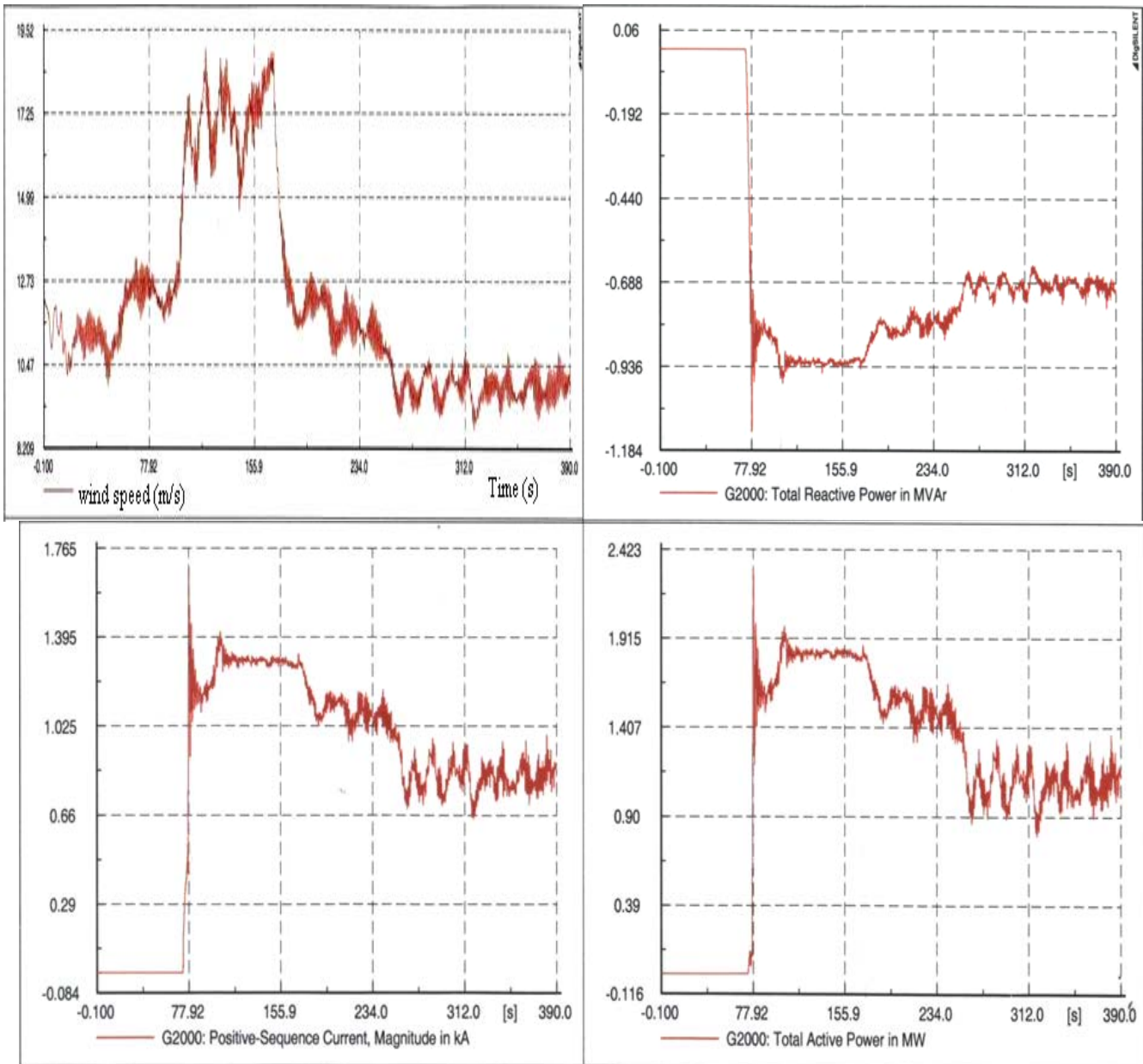

Fig. 10. Simulation results during sudden changes in wind speed for a 2MW active stall constant-speed wind turbine using CRIG.

Authors' information

¹ Dept. of Electrical Machines and Drives, "Politehnica" University of Timisoara, Romania.

² Dept. of Automation and Applied Informatics, University of Ottawa (Canada).



L. Mihet-Popa received the B.S. degree, M.S. degree and Ph.D. degree from the POLITEHNICA University of Timisoara, Timisoara, Romania, in 1999, 2000 and 2003, respectively, all in electrical engineering. He is currently working as Associate Professor in the Department of Electrical Machines and Drives, Timisoara. Dr. Mihet-Popa received in 2005 the second prize paper award of the IEEE Industry Applications Society. His research interest includes control and modeling of induction machines, detection and diagnosis of faults, especially for wind turbine applications.



Voicu Groza received the B.S. degree and Ph.D. degree from the POLITEHNICA University of Timisoara, Romania, in 1972 and 1985, respectively. He is currently working as Associate Professor in School of Information Technology and Engineering, University of Ottawa. His research interest includes real-time embedded systems, distributed intelligent instrumentation and smart sensors networks.